

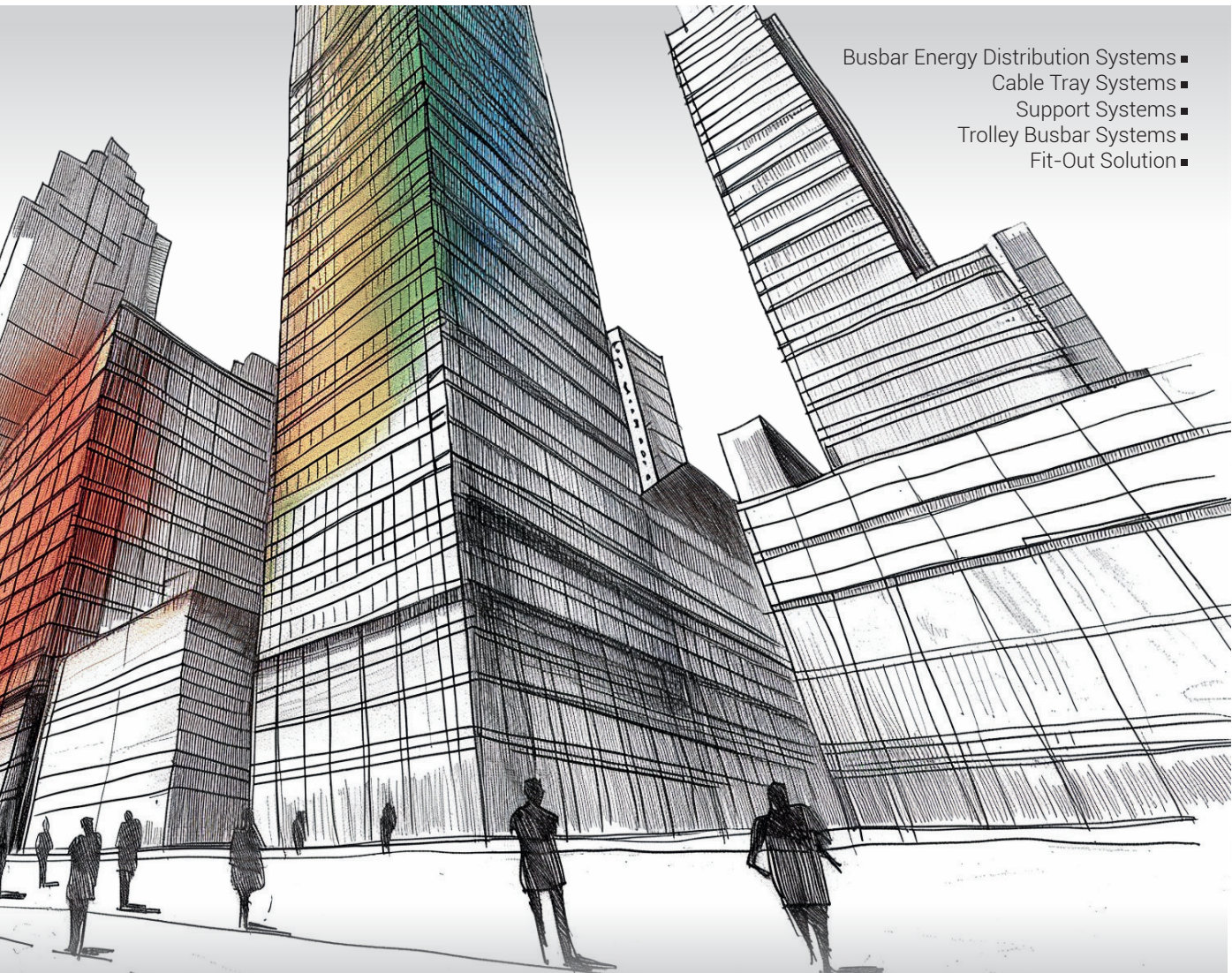

# PANORAMA



- Busbar Energy Distribution Systems
- Cable Tray Systems
- Support Systems
- Trolley Busbar Systems
- Fit-Out Solution



## EAE Group in numbers;



**1973**  
year of foundation

Founded in 1973, EAE Elektrik A.S. being the parent company of EAE Group is a worldwide manufacturer of electrical products.

**Founded** : in 1973  
**Closed Manufacturing Area** : 280.000m<sup>2</sup>  
**Range of Products** : Busbar Power Distribution Systems  
Lighting Busbar Systems  
Cable Tray Systems  
Underfloor Trunking  
Trolley Busbar Systems



**280.000m<sup>2</sup>**  
closed manufacturing  
area

**Companies** : EAE Elektrik  
EAE Aydınlatma  
EAE Elektroteknik  
EAE Teknoloji  
EAE Makina



**5**  
manufacturing  
plants

**Number of Plants** : 5

“Lean Production” and “Innovative and Customer Driven Product Development” approaches are the key values utilized in designing and manufacturing the product families in compliance with ISO 9001, ISO 14001, OHSAS 18001 and ISO 27001.



**3**  
R&D Centers

EAE Elektrik A.S. busbar products are certified by KEMA/DEKRA (Holland), KEMA - KEUR, UL classified laboratories as per IEC 61439-1/6 standards.



**100+**  
countries of export



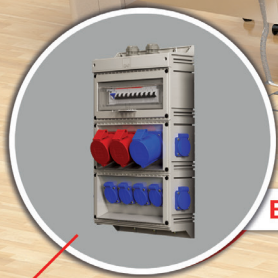

**ELINEMULTIBOX**



**ELINENDK**



**ELINESMART**

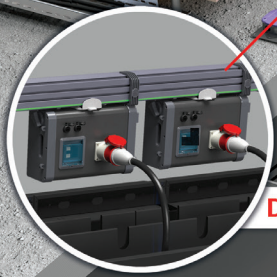

**DATARACKBUSBAR**

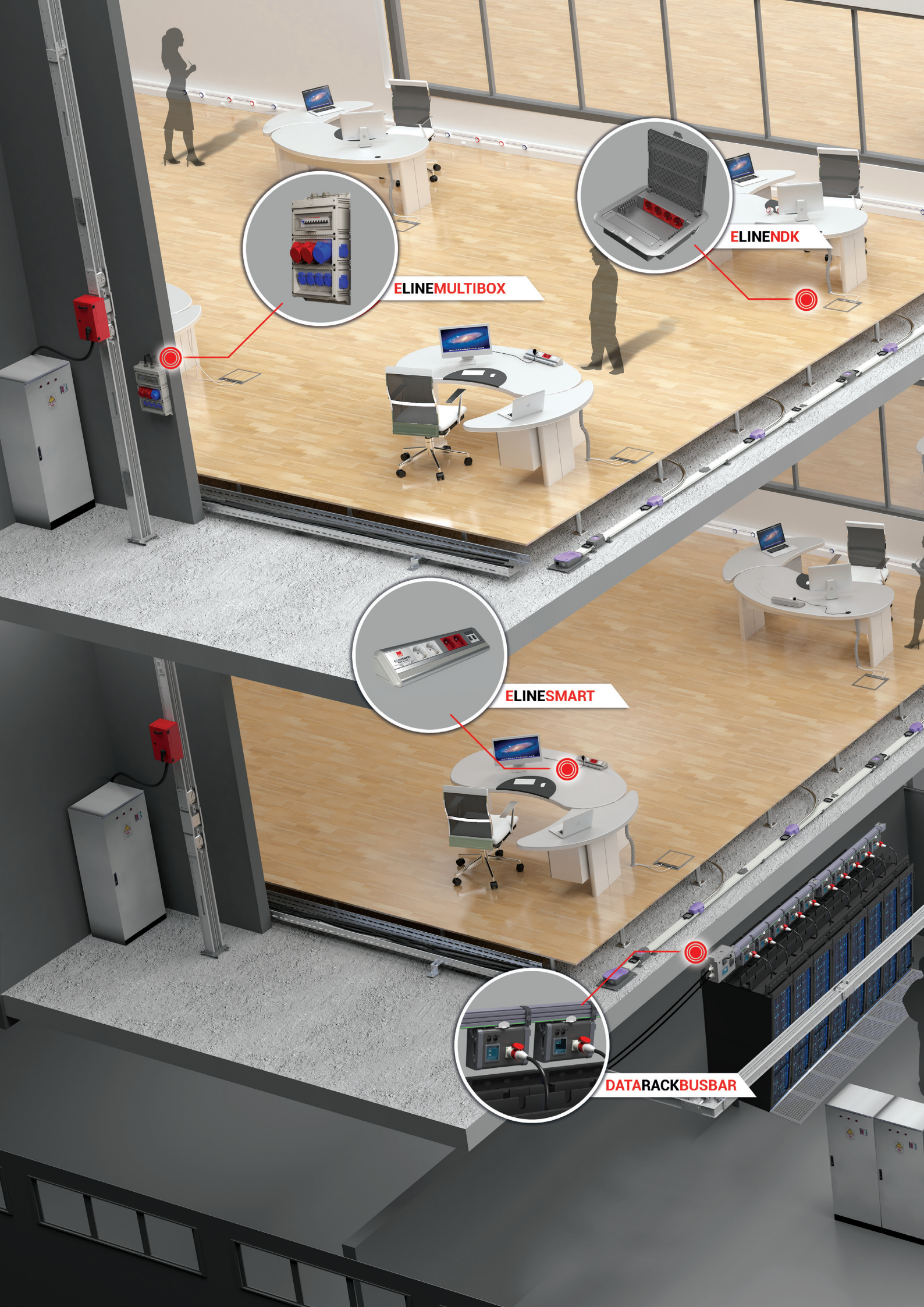



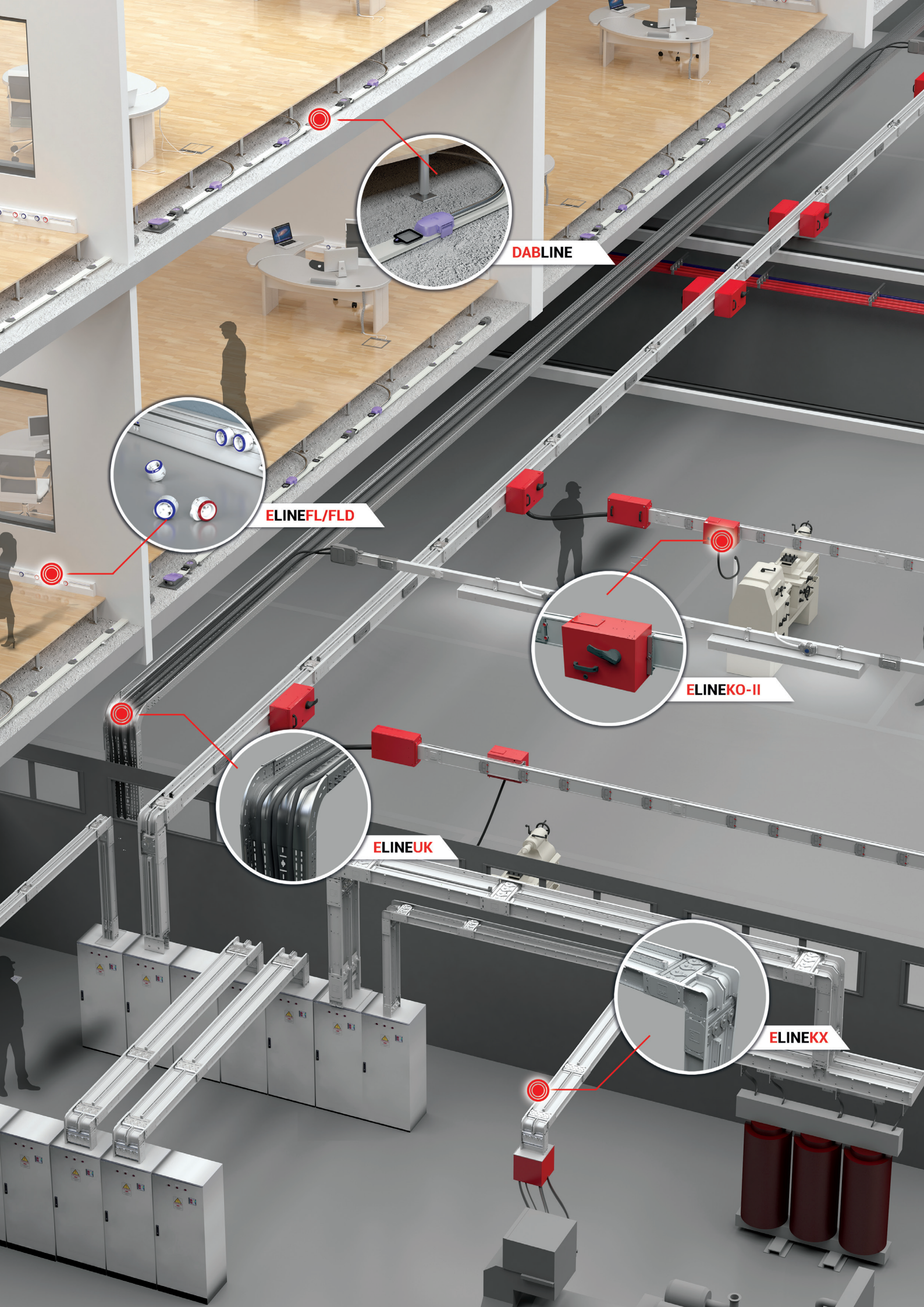

**DABLINE**

**ELINEFL/FLD**

**ELINEKO-II**

**ELINEUK**

**ELINEKX**



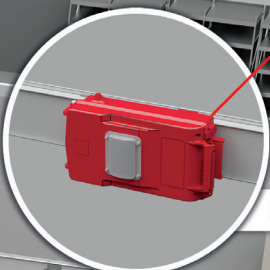

**ELINEMK**

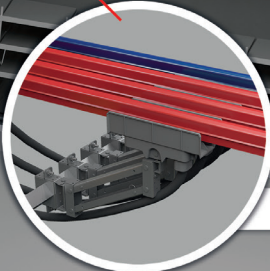

**ELINEURC**



**REVOLED-X**

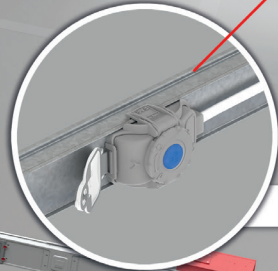

**ELINEDL**

# ENERGY DISTRIBUTION SYSTEMS...



# BUSBAR ENERGY DISTRIBUTION SYSTEMS



## ELINEKX Compact Busbar Distribution Systems 400A...6300A

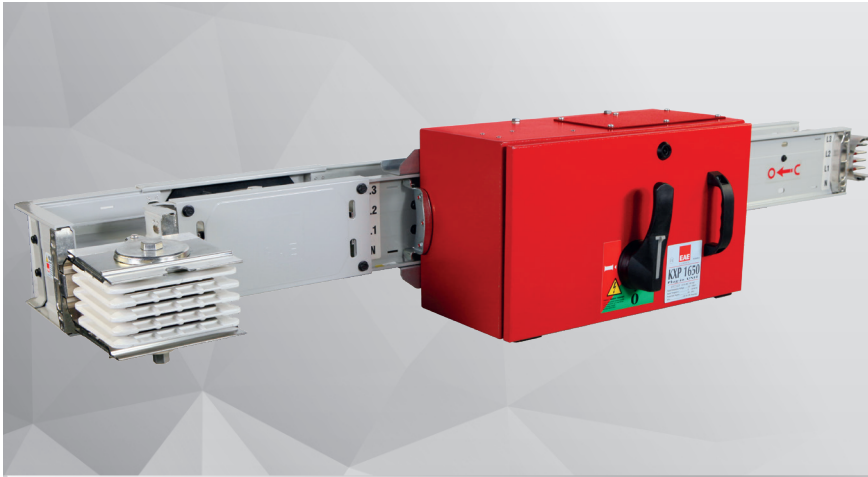

### Overview

The EAE E-Line KX Series compact busbar system is designed for use in projects requiring high power distribution, and is rated from 400A to 6300A using the latest technology.

### Features:

- Modular structure
- Ability to supply energy either from the joints or from the tap-off points (Bolt-on or Plug-in)
- High electrical and mechanical strength
- The compact structure offers many benefits in the installation.
- Fast, easy and reliable installation with single bolt joint construction.
- Output units allow a significant saving about panel and system cost.
- Special design for minimal voltage drop
- Tin plated aluminium or copper conductors
- IP55 protection degree
- Aluminium housing
- Epoxy insulation
- Fire resistance as per IEC 60331

### Advantages of E-Line KX Compact Busbar:

- High short circuit resistance due to compact construction
- Less voltage drop in comparison to cable systems
- Special alloy metal enclosure provides higher mechanical strength and causes less electromagnetic interference.
- Better cooling capability
- High resistance to fire
- Seismic resistance
- Protection Degree (IP55 standard and IP67 optional)
- Requires less space in comparison to cable systems

### Applications:

- Production areas in factories
- Textile factories
- Furniture factories
- Automotive and automotive sub-industries
- Malls
- Exhibition areas
- High rise buildings
- Hotels
- Hospitals
- Business centres





# BUSBAR ENERGY DISTRIBUTION SYSTEMS



## ELINECCR Compact Busbar Distribution Systems 600A...6300A

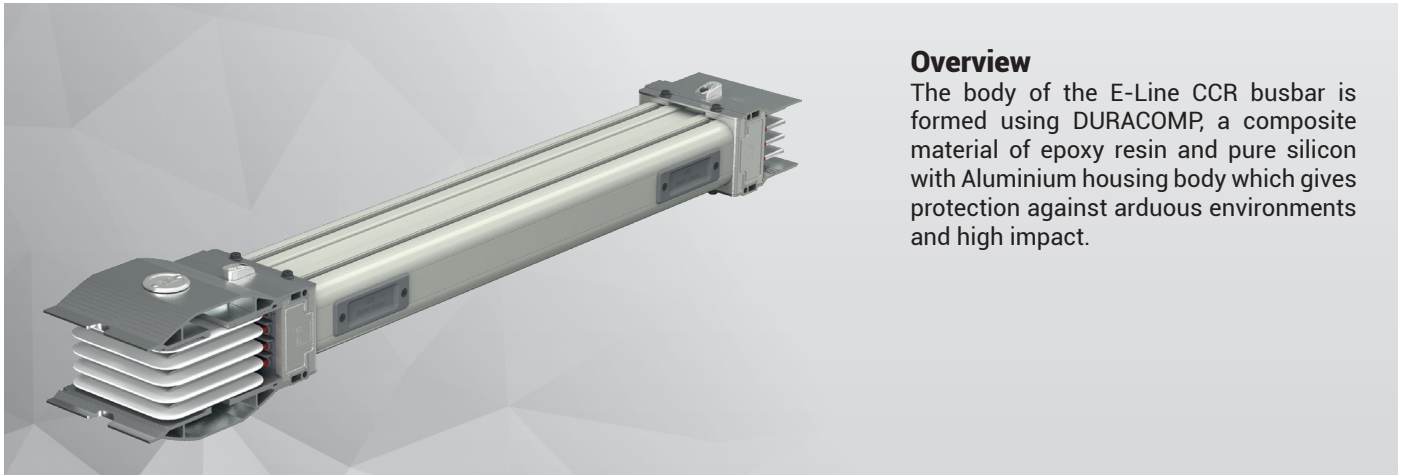

### Overview

The body of the E-Line CCR busbar is formed using DURACOMP, a composite material of epoxy resin and pure silicon with Aluminium housing body which gives protection against arduous environments and high impact.

### Features:

- CCRC Current ranges for Copper conductor series; 650A / 850A / 1000A / 1250A / 1600A / 2000A / 2500A / 3200A / 3400A / 4000A / 4500A / 5000A / 5750A / 6300A
- CCRA Current ranges for Aluminum conductor series; 600A / 800A / 1000 / 1250A / 1600A / 2000A / 2500A / 3000A / 3300A / 3600A / 4000A / 4500A / 5000A / 5400A
- IP68 protection degree
- 3, 4, 4,5 and 5 conductor options
- Clean earth option

### Applications:

- Outdoor Environments
- Oil and gas plants
- Nuclear plants
- Cement plants
- Power plants
- Harbours and shipyards
- Food processing plants
- Tunnels and underpasses

### Fire and Earthquake Resistance

IEC 60331 -1, 3 hours of continuous current under fire condition  
2 hours current continuity according to BS 8602 standard  
Seismic Resistance as per IEC 60068-3-3 / 60068-2-57 and IEEE 693



II 2G Ex mb IIC Gb  
II 2D IIIC Db

### EX - Protected

ATEX according to EN 60079-0:2009, EN 60079-18:2009, EN60079-31:2009

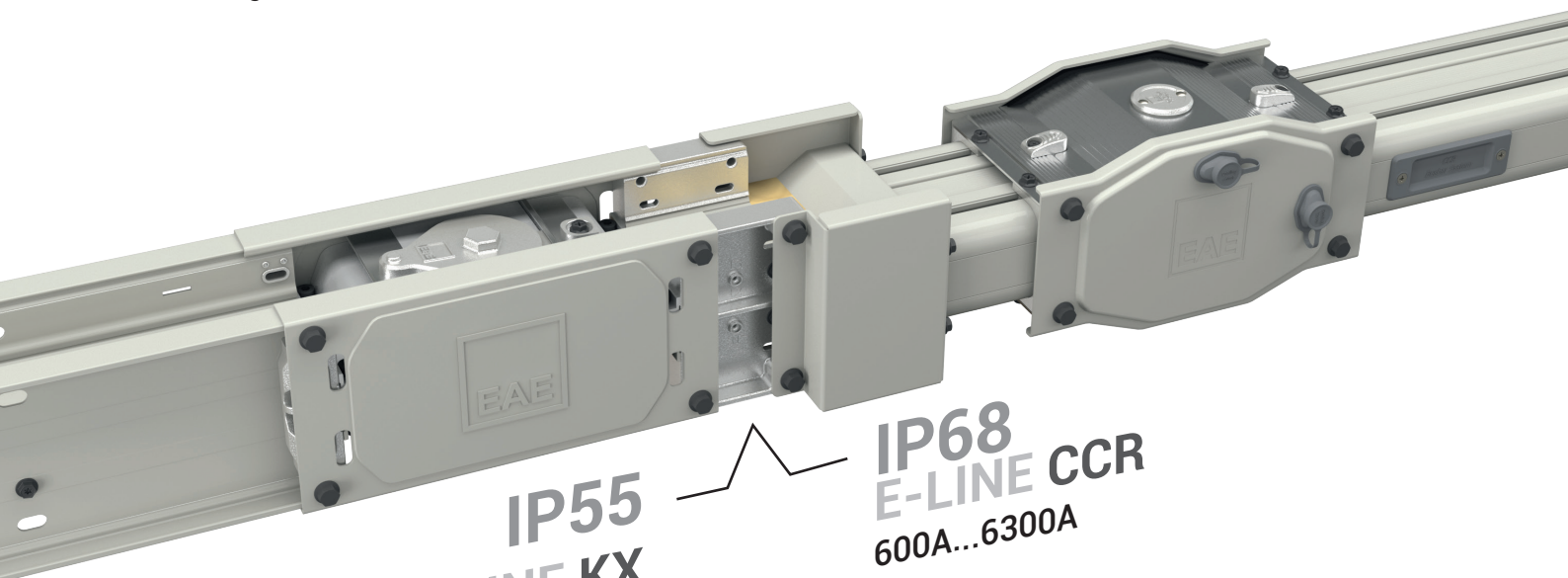

**IP55**  
**E-LINE KX**  
400A...6300A

**IP68**  
**E-LINE CCR**  
600A...6300A

### E-LINE CCR-KX

CCR-KX transition module offers the possibility of reducing time and cost with direct installation.



## **ELINECR** Compact Busbar Distribution Systems 630A...6300A



### Overview

The body of the E-Line CR busbar is formed using DURACOMP, a composite material of epoxy resin and pure silicon which gives protection against arduous environments and high impact.

### Features:

- Current ranges for CRA Aluminium conductor series; 630A / 800A / 1000A / 1250A / 1600A / 2000A / 2250 A / 2500A / 3000A / 3200A / 3600A / 4000A / 5000A
- Current ranges for CRC Copper conductor series; 800A / 1000A / 1250A / 1600A / 2000A / 2500A / 3000A / 3200A / 3600A / 4000A / 5000A / 6300A
- IP68 protection degree
- 3, 4, 5 and 6 conductor options
- Clean earth option

### **Fire and Earthquake Resistance**

IEC 60331-1, 3 hours of continuous current under fire condition  
Seismic Resistance as per IEC 60068-3-3 / 60068-2-57 and IEEE 693.

### **EX - Protected**

ATEX according to EN 60079-0:2009, EN 60079-18:2009, EN60079-31:2009

### Applications:

- Links between transformers and switchboards
- Oil and gas plants
- Nuclear plants
- Cement plants
- Power plants
- Harbours and shipyards
- Food processing plants
- Tunnels and underpasses

### **DIN 4102-12**

System Integrity Under Fire

E60 = Standard

E120 = External Protection Support

## **ELINEMV** Medium Voltage Busbar Distribution Systems 950A...5700A

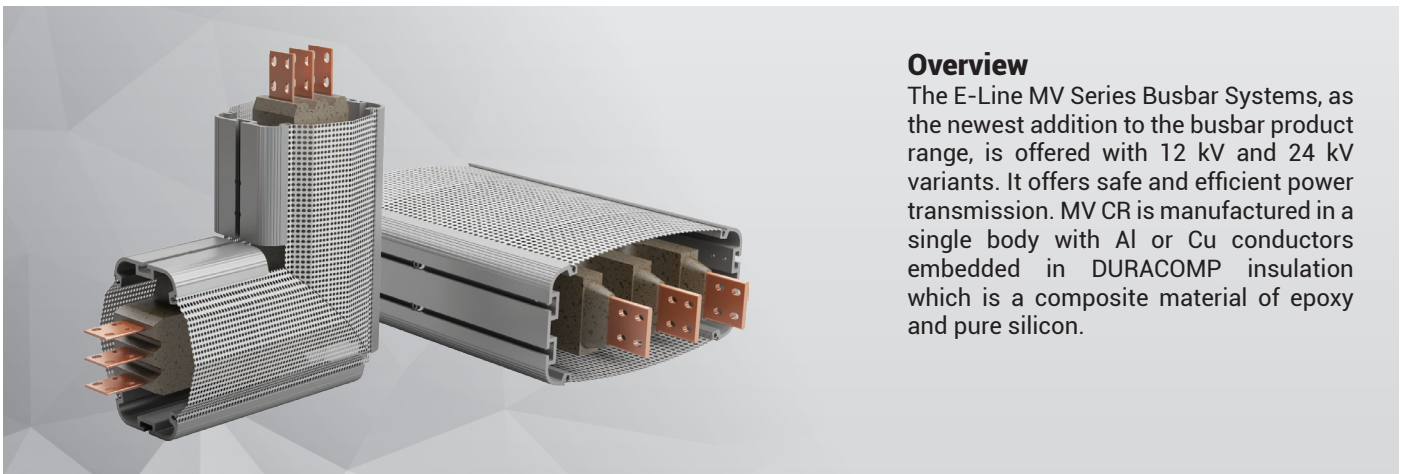

### Overview

The E-Line MV Series Busbar Systems, as the newest addition to the busbar product range, is offered with 12 kV and 24 kV variants. It offers safe and efficient power transmission. MV CR is manufactured in a single body with Al or Cu conductors embedded in DURACOMP insulation which is a composite material of epoxy and pure silicon.

### Features:

- 12 kV and 24 kV variants
- DURACOMP composite body
- Ex-proof
- IP68 protection degree

### Applications:

- Outdoors
- Industrial buildings
- Petrochemical Industry
- Areas with flood risk
- Oil and natural gas Industry
- Power Generation Industry
- Data centers



## ELINEKL Busbar Distribution Systems 160A...1200A

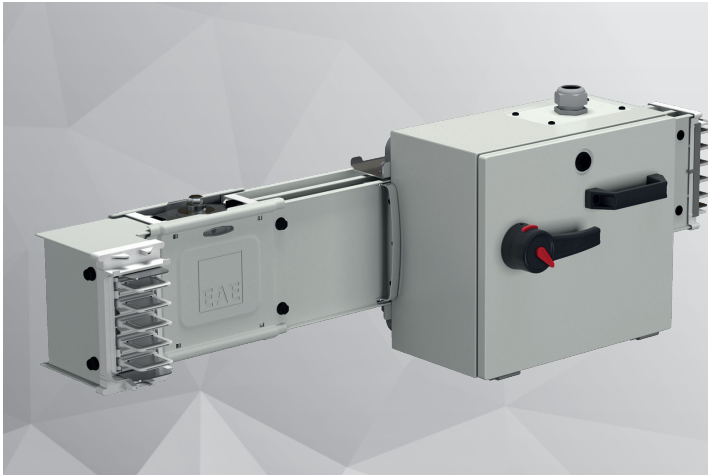

### Overview

The “E-Line KL Series” medium-range busbar systems are used in medium-sized buildings or industrial facilities, providing suitable solutions for electrical transmission and distribution in horizontal or vertical applications.

They offer significant cost savings by using fuse-switch disconnectors/MCCBs (Molded Case Circuit Breakers) with metal boxes or plastic boxes compatible with MCB (Miniature Circuit Breaker) switches for smaller currents, according to specific needs.

### Features:

- Modular structure
- Plug-in tap off outlets at every 25cm
- Aluminium or copper conductors
- 4, 4,5 or 5 conductors
- Tin plated conductors
- Dust cover on outlet points
- IP55 protection class

### Applications:

- Production areas in factories
- Textile plants
- Furniture plants
- Automotive plants
- Automotive sub-industry
- Shopping centres
- Exhibition centres
- High-rise buildings
- Hotels
- Hospitals
- Business centres
- Data centres

## ELINEKO-II Busbar Distribution Systems 160A...800A

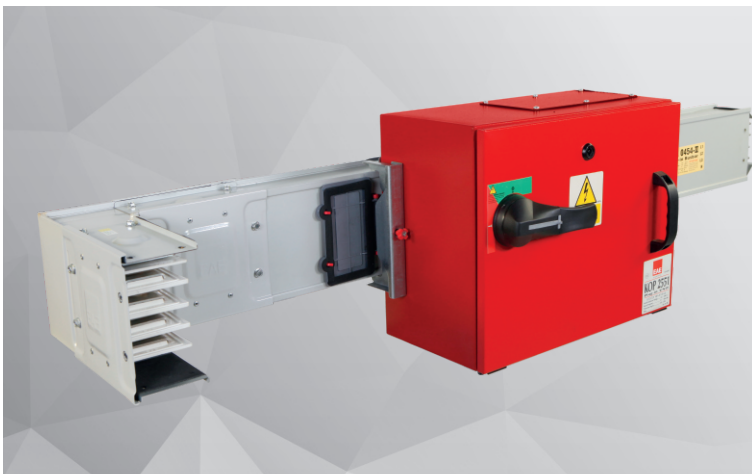

### Overview

“E-Line KO Series” medium range busbar systems provide suitable solutions for electricity transmission and distribution in medium-sized buildings or industrial facilities. They can be used in horizontal or vertical applications. Tap off box solutions comprise sheet metal boxes with circuit breakers, or plastic boxes for small currents which are compatible with Miniature Circuit Breakers.

### Features:

- Modular structure
- Plug-in tap off outlets at every 25cm
- Aluminium or copper conductors
- 4, 4,5 or 5 conductors
- Tin plated conductors
- Dust cover on outlet points
- IP55 protection class

### Applications:

- Production areas in factories
- Textile plants
- Furniture plants
- Automotive plants
- Automotive sub-industry
- Shopping centres
- Exhibition centres
- High-rise buildings
- Hotels
- Hospitals
- Business centres
- Data centres



# BUSBAR ENERGY DISTRIBUTION SYSTEMS



## ELINEKD Data Rack Busbar Systems 160A...1000A

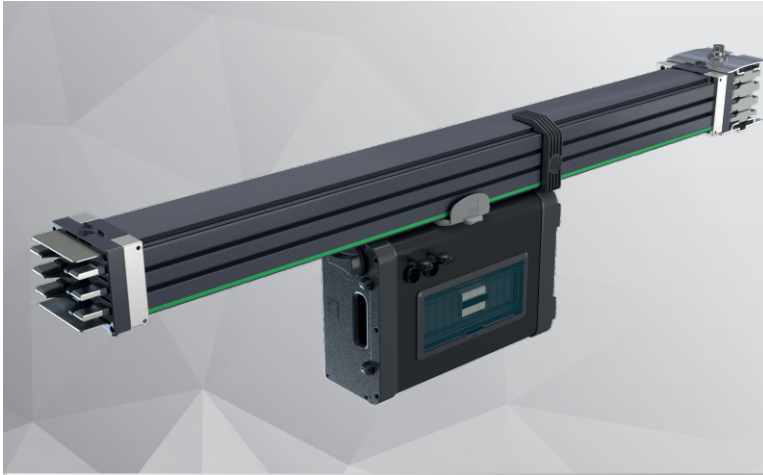

### Overview

To power the mission critical IT infrastructures, EAE offers a highly flexible Busbar Systems for reliable and energy efficient operations in your Healthcare System's Data Centers.

### Features:

- Plug-n-play anywhere along the bar
- Protected Tap-Off Contacts
- Tap-Off contacts with heat cycle testing
- Al and Cu conductor options
- Safe Alignment mechanism ensures correct installation and operation
- Special interlock mechanism enabling to carry the weight of the plug-in box and cables by the busbar housing
- Up to 6 conductor option
- IP23D protection

### Applications:

- Data Center
- White space general usage
- White space points which requires high density usage of tap-off boxes

## ELINEMK Busbar Distribution Systems 100-160-225A



### Overview

The small power range busbar systems of "E-Line MK Series" provide flexible and cost-effective solutions for the transmission and distribution of electricity in small-sized enterprises, workshops and industrial facilities.

### Features:

- Modular structure
- Plug-in tap off outlets at every 25cm on both side
- Tin plated aluminium or copper conductors
- 4 or 5 conductors
- Hinged and lockable dust cover on outlet points
- Installation without using a torque wrench (shearhead bolts)
- IP55 protection class
- Flexible elbows and expansion modules

### Applications:

- Small enterprises
- Local production areas in factories
- Workshops
- Textile plants
- Automotive plants
- Automotive sub-industries
- Small-sized industrial plants
- Shopping centres
- Large markets
- Data centres



## ELINEKY-S Lighting & Low Power Distribution Systems 25-40-63A

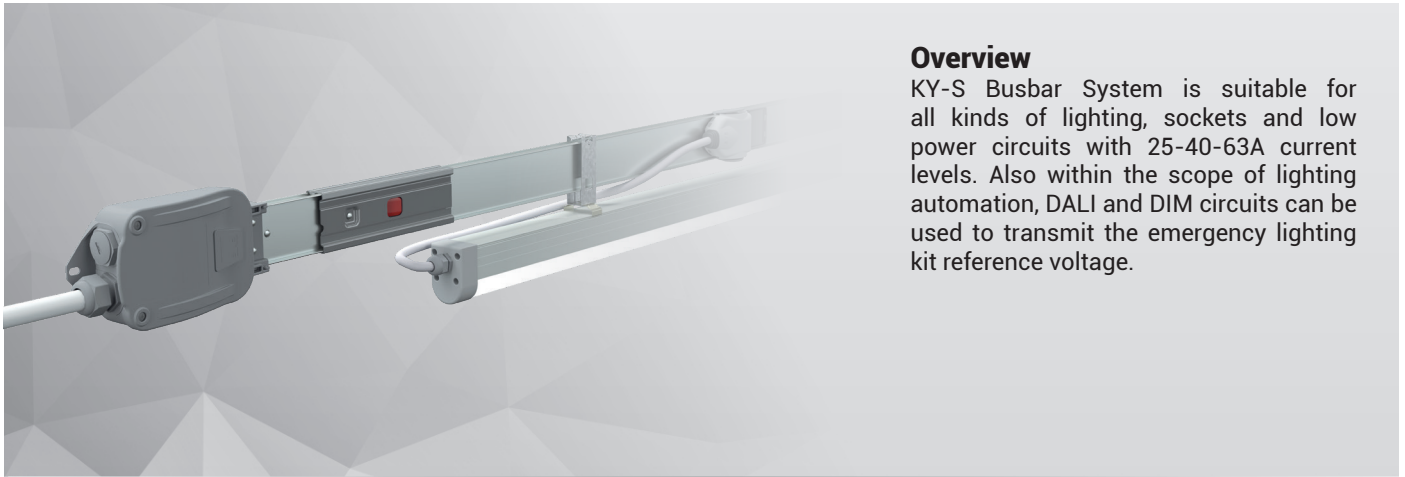

### Overview

KY-S Busbar System is suitable for all kinds of lighting, sockets and low power circuits with 25-40-63A current levels. Also within the scope of lighting automation, DALI and DIM circuits can be used to transmit the emergency lighting kit reference voltage.

### Features:

- 3 and 4m standard busbar length, plug-in points every 1m,
- At all joint and plug-in points, the contacts are plated with silver,
- Copper conductors are covered with full length tin and copper oxide formation is prevented,
- Simple joint structure that prevents deflection and stretching.

### Applications:

- Offices
- Business centers
- Banks
- Schools
- Conference centers
- Car Park

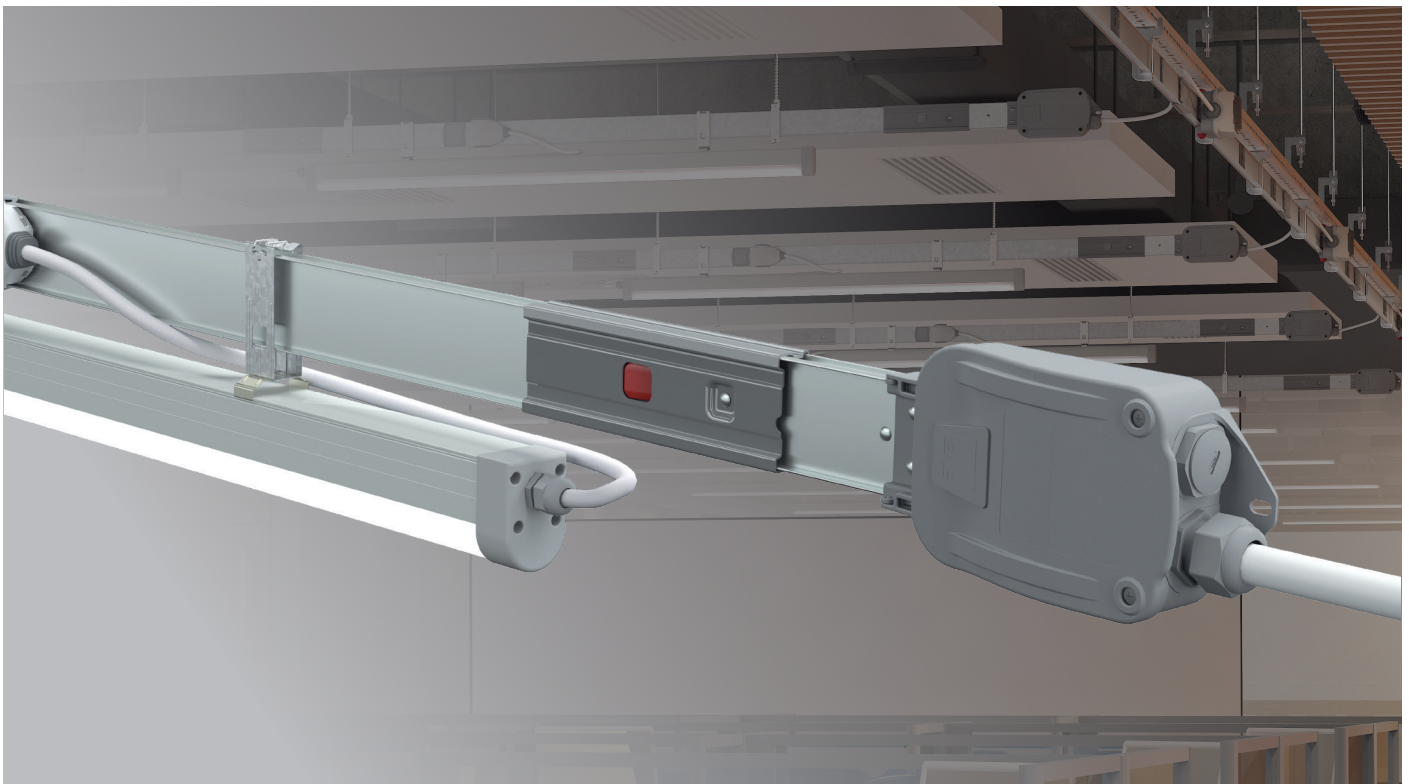



## ELINEDL/SL Multi-conductor Lighting Busbar Systems 25-32-40A

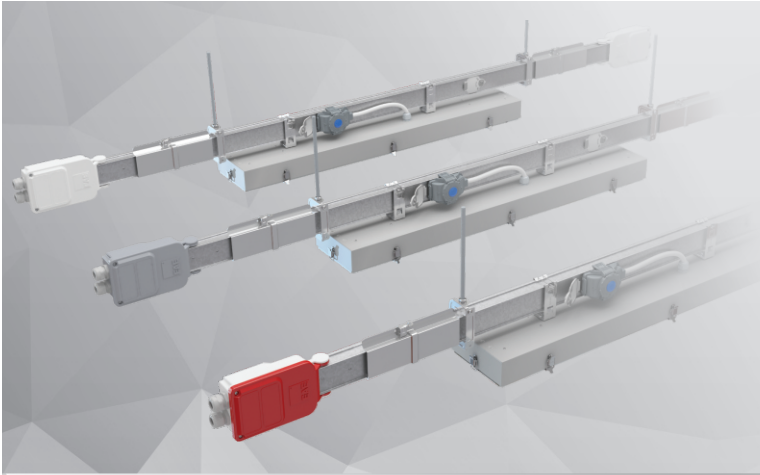

### Overview

The E-Line DL range of busbar systems are used in buildings on lighting and socket circuits where 25A, 32A or 40A Three-phase or Single-phase power is required. 10-16A plugs or 25A tap-off boxes with a cartridge fuse or miniature circuit breaker are specially designed to supply lighting and power circuits as per the specifications.

### Features:

- Choice of conductor configurations up to 10 conductors with 5+5 form
- Fast, easy and reliable installation
- Tap-off plugs are available in different colours to indicate the phases
- Strong body structure which can support all types of luminaires
- Double-sided 8 output points on busbar (DL)
- IP 55 protection class
- Clean Earth "CE" conductor for UPS circuit
- SL Busbar offers an affordable solution with the option to draw current from a total of 4 tap off points per 3m length.
- The Emergency Kit (ACK) supply and the Dali signal are fed through the same busbar and tap off plug negating the need for extra cabling.

### Applications:

- Offices
- Business centres
- Banks
- Schools
- Congress halls

## ELINEKAP Plug-in Busbar Distribution Systems 40A-63A



### Overview

The E-Line KAP small power busbar range offers extremely economical solutions for the distribution of power in small enterprises and confection plants. The KAP range is ideally suited to supply low power machinery such as sewing machines, hand tools and machine tools.

### Features:

- Conductors are electrolytic copper tin plated and insulated along their full length with a self-extinguishing plastic sleeve. (formation of copper oxide is inhibited)
- Fast, easy and reliable installation
- Standard 4 or 5 conductor.
- Tap-off plugs are available in different colours to indicate the phases
- Plugs and tap-off boxes are designed with different contact sequences to avoid interchangeability problems
- The joint contacts are silver plated and highly oversized in comparison with the nominal current to withstand in total safety possible short term current peaks
- One plug-in output point at standard 75cm intervals
- Manufactured in accordance with IEC 61439-6 standard. It has DEKRA and TSE certifications.
- Offering output from from tap off plugs or boxes with 16A and 32A cylinder fuse or miniature circuit breaker (MCB) and connectors

### Applications:

- Production and storage areas in factories
- Workshops
- Confection plants
- Parking areas
- Raised floors in offices
- Logistics warehouses
- Large markets
- Malls



## ELINEUKE Cable Tray Systems

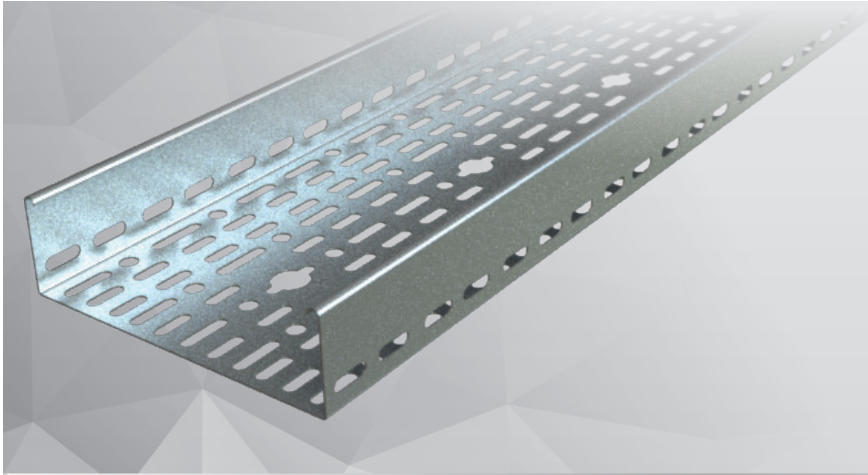

### Overview

The E-Line UKE series pre-galvanized cable trays are produced in a standard heavy-duty type according to TSE (Turkish Standards Institution), TS EN 10346, and ISO 10143 standards. Manufactured through the "Roll Forming" method, they are produced as a single piece up to a length of 6m. The standard length is 3m. They are designed to carry cable installations in internal environments within facilities and buildings.

### Features:

- Heavy duty type
- Standard 40/50/60/75/100mm heights produced
- 50/100/150/200/250/300/400/500/600mm widths
- 0,8/1/1,2/1,5/2mm thickness
- 3000/4000/5000/6000mm lengths
- According to the TS EN 10346 and TS EN 10143 standards galvanized option (pregalvanized)
- Possibility to connect the various accessories that 20,5 diametres hole in the middle of the tray
- Wide range of accessories
- Fire resistance certificates (E30-E60-E90)
- Galvanized steel painted finish available on request (epoxy, epoxy polyester, polyester)

### Applications:

- Warehouses
- Workshops
- Car parking areas
- Markets
- Business centres
- Industrial plants
- Similar work places and spaces

## ELINEUKFG Cable Tray Systems

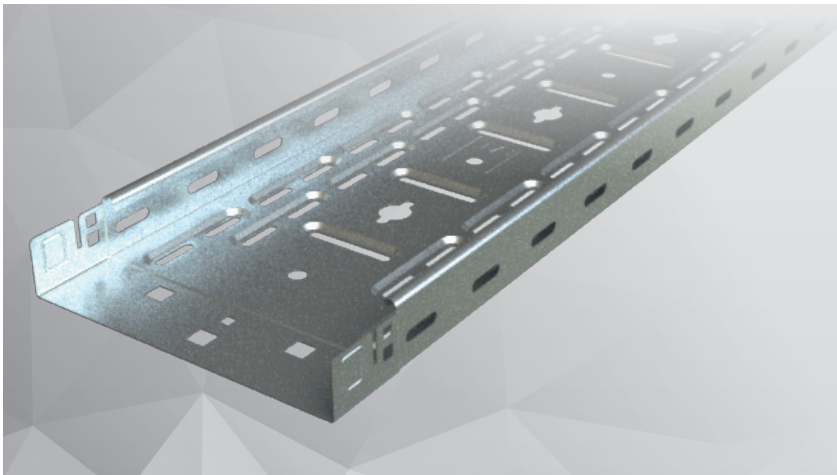

### Overview

E-LINE UKFG systems can be connected with a bolt without the need for any an additional equipment thanks to its snap on system on the edges. It offers the greatest savings with minimum installation time thanks to its minimum thickness and minimum costs and simple installation on site.

### Features:

- Heavy duty type
- 40/50/60/75/100mm heights
- 100/200/300/400/500/600mm widths
- 100/200/300mm widths 0,7mm and 400/500/600mm widths 0,9mm thicknesses
- Thanks to special forming of the edges of the tray lengths, it can bear the load equal to the products with standard thickness
- Thanks to its snap on system, easily mounted without the need for additional elements
- Wide range of accessories
- Fire resistance certificates (E30-E60-E90)

### Applications:

- Parking areas
- Hotels, housing
- Factory and industrial plants
- Food processing plants

## ELINEKM Pre-galvanized Foldable Cable Ladders

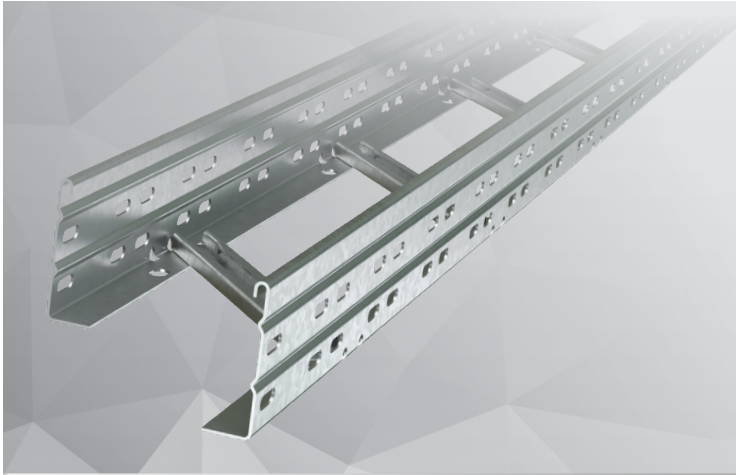

### Overview

E-Line KM pre-galvanized foldable cable ladders are featured with one-way folding. Thanks to this, they take up much less space than the E-Line KC series cable ladders. This reduces shipment and storage costs.

### Features:

- Heavy duty type
- 40/50/60/75/100/125/150mm heights
- 100/200/300/400/500/600 widths (700-800-900-1000 special widths on request)
- 3000mm length (6000mm special length on request)
- TS EN ISO 1461 standard hot-dip and TS EN 10346, TS EN 10143 standart pre-galvanized production.
- Load carrying capacity can be increased by giving shape to the sheet iron.
- Products can be used along the side walls in horizontal suspended application. Thereby provides a significant cost advantage.
- 300mm equally spaced traverse structure
- More cable space than traditional ladders with special traverse height
- Fire resistance certificates (E30-E60-E90)

### Applications:

- Suitable for internal and external environment
- Industrial plants
- Skyscrapers
- Textile and confection plants
- Automotive plants
- Shopping centres
- Hospitals
- Conference centres
- Parking areas
- Oil & Gas plants
- Tunnels; rail systems, bridges, underpasses

## ELINETKS Pre-galvanized and Hot-dip Trunking Systems

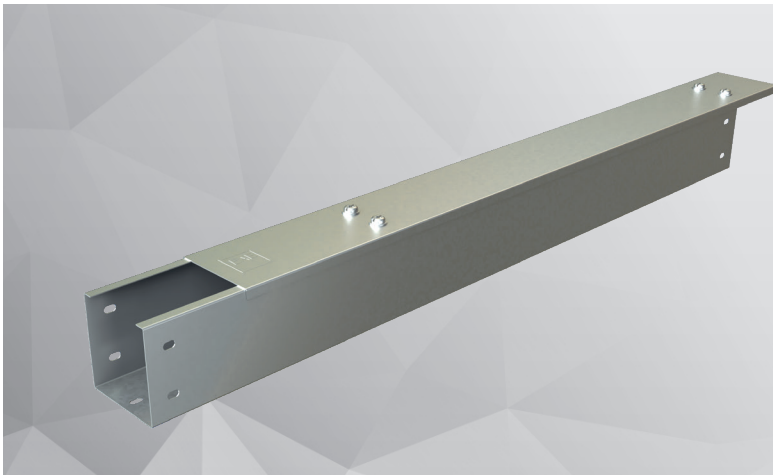

### Overview

E-Line TKS series trunking cover cable trays systems are used for cabling in indoor environments. They are manufactured as pre-galvanized or Hot dip. The cover is easily mounted thanks to the special lock system. Mounting the modules on trays is quick and simple.

### Features:

- Heavy duty covers and locked non perforated structure
- 3 locking points every 3m
- Possibility of the quick lock cover
- H:50-75-100-150 and 200mm heights
- 50/75/100/150/200/300mm widths
- 1mm, 1,2mm and 1,5mm thickness
- Providing resistance to the passage of the grounding continuity reducer coupling (which is important for data and telephone cables)
- 3000mm lengths
- TS EN ISO 1461 standard hot-dip and TS EN 10346, TS EN 10143 standart pre-galvanized production
- Wide range of accessories

### Applications:

- Acceptable internal environment
- Connection between machines
- Banks (IT centres)
- Required mechanical and UV protection areas



## ELINEKME Hot-dip Galvanized Cable Ladders

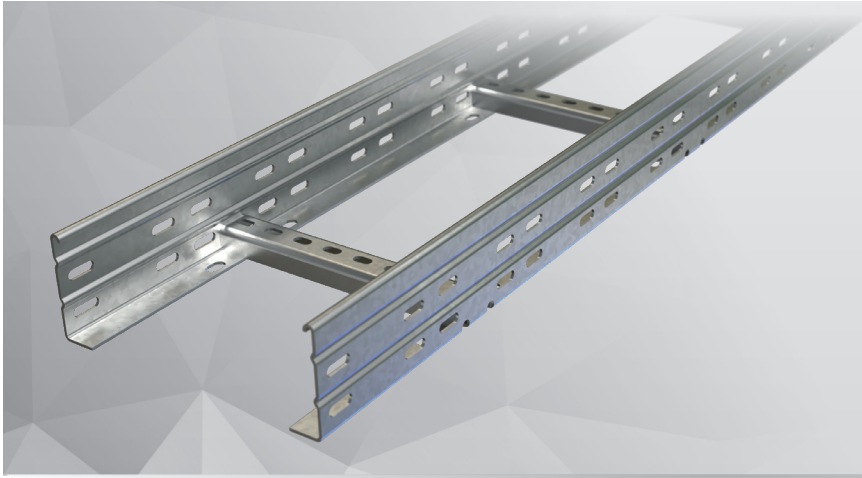

### Overview

E-Line KME cable ladders are designed to route the cabling in facilities and buildings in internal or external environments on vertical shafts thanks to its high load bearing capacity.

### Features:

- Heavy duty type
- 40/50/60/75/100/125/150mm heights
- 50/100/150/200/250/300/400/500/600mm widths
- With Binrak traverse with 700/800/900 width options, high bearing capacity (KME)
- 1,2/1,5/2mm thickness
- Load carrying capacity can be increased by giving shape to the sheet iron.
- 300mm equally spaced traverse structure
- TS EN ISO 1461 standard hot-dip production
- Wide range of accessories
- Fire resistance certificates (E30-E60-E90)
- Galvanized steel painted finish available on request (epoxy, epoxy polyester, polyester)

### Applications:

- Suitable for internal and external environment
- Industrial plants
- Skyscrapers
- Textile and confection plants
- Automotive plants
- Shipyards
- Malls, hospitals
- Conference centres
- Car parking areas
- Oil&Gas plants
- Tunnels; rail systems, bridges, underpasses

## ELINECT Hot-dip Galvanized Cable Tray Systems

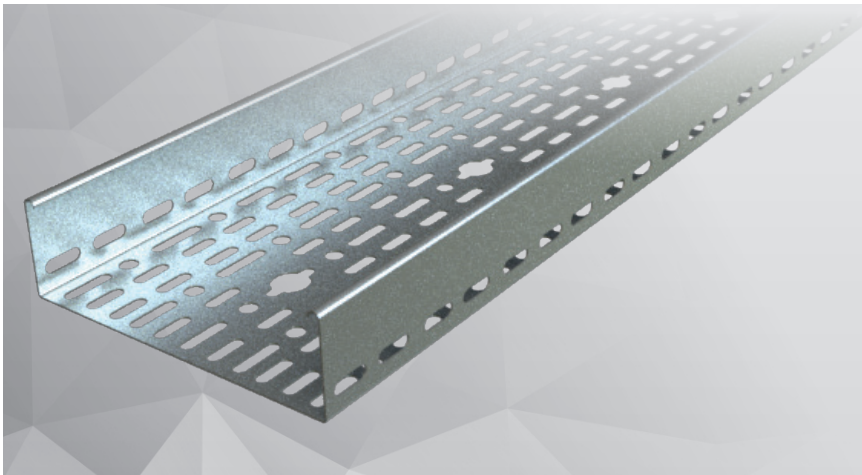

### Overview

E-Line CT series hot-dip galvanized cable trays are designed to carry the cabling in indoor or outdoor installations internally or externally in factories and buildings, especially in humid or vaporous environments. They can also be manufactured as pre-galvanized upon request.

### Features:

- Heavy duty and regular types
- 40/50/60/75/100/125/150mm tray heights
- 50/100/150/200/250/300/400/500/600 widths (700-800-900 special widths on request)
- 0,8/1/1,2/1,5/2mm thickness
- 3000mm length (6000mm special length on request)
- TS EN ISO 1461 standard hot-dip and after special EAE protective coating over hot dip
- Possibility to connect the various accessories that 20,5 diametres hole in the middle of the tray
- Wide range of accessories
- Fire resistance certificates (E30-E60-E90)
- Galvanized steel painted finish available on request (epoxy, epoxy polyester, polyester)

### Applications:

- Suitable for internal and external environment
- Industrial plants
- Skyscrapers
- Textile and confection plants
- Automotive plants
- Shipyards, airports
- Malls, hospitals
- Conference centres
- Car parking areas
- Oil&Gas plants
- Tunnels; rail systems, bridges, underpasses

## ELINECTK Hot-dip Snap On Covered Cable Duct Systems



### Overview

E-Line CTK series hot dip snap on cover cable tray systems can be easily mounted without the need for cover fixings thanks to the special bends on the cover and the tray.

### Features:

- Heavy duty type
- 60 / 75 / 100mm heights
- Thickness: 1.5mm for 100/150/200/250/300mm 2mm for 400/500/600mm
- 3000mm length (6000mm special length on request.)
- Plug cover structure
- TS EN ISO 1461 standard hot-dip and after special EAE protective coating over hot dip
- Possibility to connect the various accessories that 20,5 diametres hole in the middle of the tray (Allows fast mounting for devices such as lighting panel, fire detector etc.)
- Wide range of accessories
- Fire resistance certificates (E30-E60-E90)
- Galvanized steel painted finish available on request (epoxy, epoxy polyester, polyester.)

### Applications:

- Parking areas
- Chemical plants
- Factory and industrial facilities
- Food plants
- Power plants

## ELINETLS Wire Mesh Cable Trays



### Overview

E-line TLS series wire mesh cable trays allows for downward outputs and to the right or left between the wires to be easily made thanks to the cage structure of wire mesh tray systems. Products are produced as stainless steel or electro-galvanized plated options.

### Features:

- 35-55-85-100mm heights
- 4-5mm thicknesses of horizontal and vertical wires
- Product structure is formed by a combination of wires from 100mm in the vertical direction, 50mm in the horizontal direction.
- Electro-galvanized and stainless production (hot-dip on request)
- Possibility of ready to turn components, external cutting-combining methods and modules.
- 3000mm length

### Applications:

- Food plants
- Data computing rooms
- Raised floor applications



# CABLE TRAY SYSTEMS



## **ELINEKCA-CTN**GRP Non-metallic Cable Management Systems Pultruded Fiberglass Reinforced Polyester

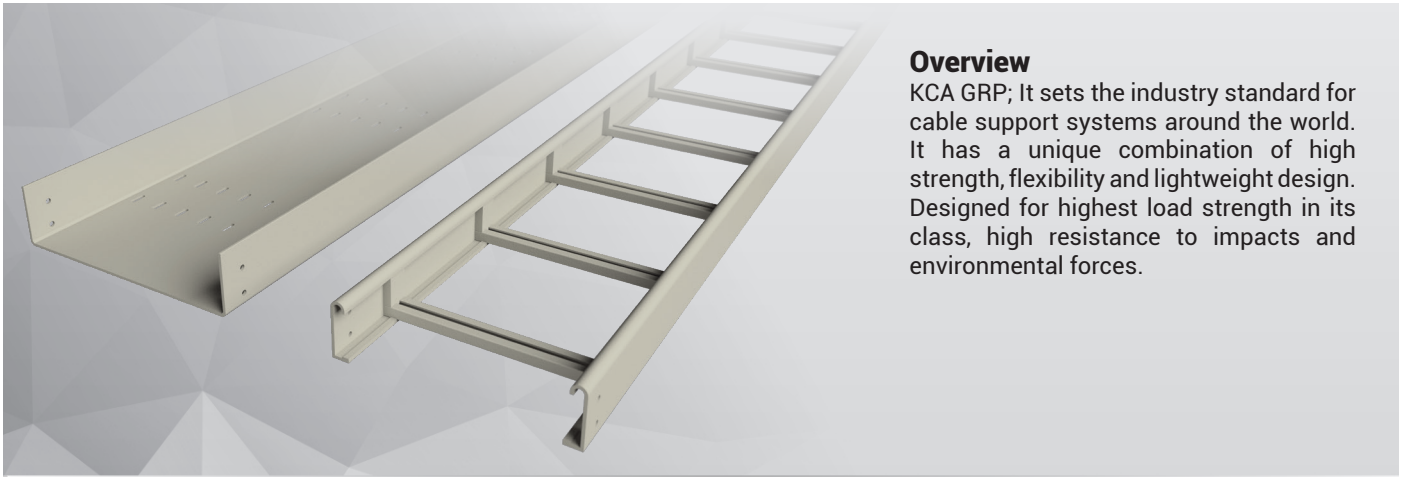

### Overview

KCA GRP; It sets the industry standard for cable support systems around the world. It has a unique combination of high strength, flexibility and lightweight design. Designed for highest load strength in its class, high resistance to impacts and environmental forces.

### Features:

- Non-flammable material (Class I – ASTM E84)
- Self-extinguishing (UL 94 "V0" Classified)
- When exposed to flame, No toxic fumes.
- Zero halogen
- Low flame spread index
- Low smoke density
- Insulating
- Extremely-light weight

### Applications:

- Tunnels
- Mining industry
- Thermal power plants
- Chemical power plants
- Geothermal power plants
- Hydroelectric power plants
- Nuclear power plants
- Heavy industrial manufacturing facilities
- Refineries
- Oil platforms
- LNG terminals and pump stations
- Urea and ammonia production facilities
- FSRU projects
- Floating power plants

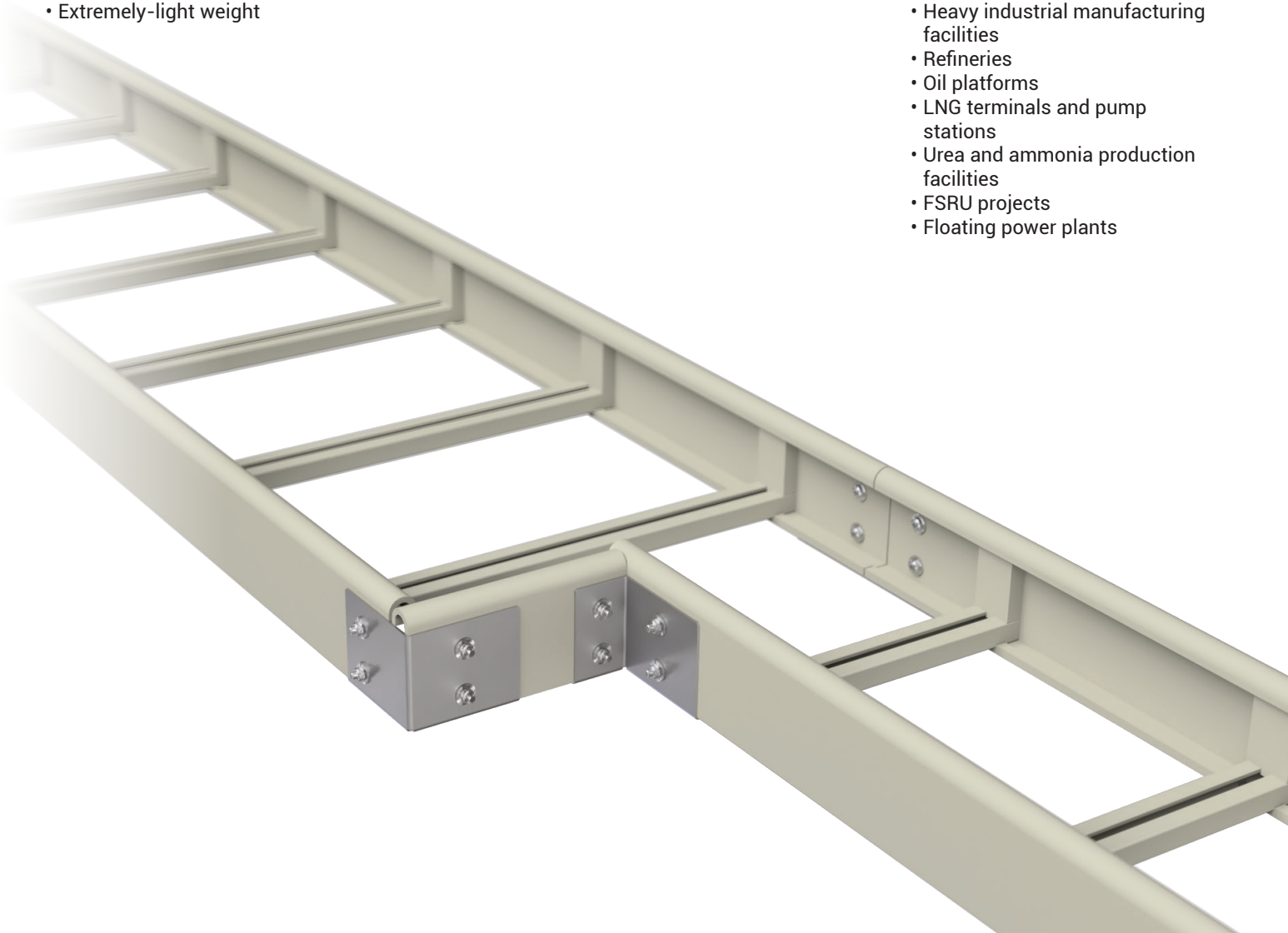

## ELINEKCA OG Cable Ladder Systems

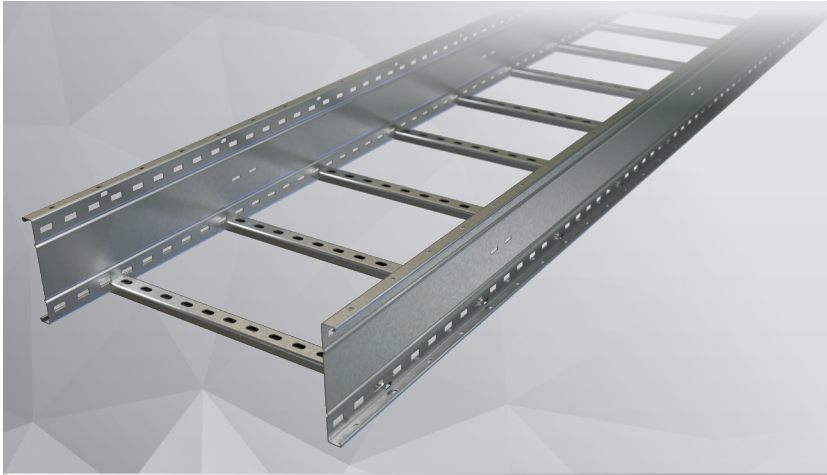

### Overview

E-Line KCA OG has a reputation for setting the industry standard for cable support systems across all around world. E-Line KCA OG has a unique combination of high strength, resilience, and lightweight design. E-Line KCA OG Cable Ladder range is engineered for the ultimate load bearing strength in its class, high resistance to impact and environmental forces, while also achieving all weight reductions possible.

### Features:

- 6mt the is standard length and construction of the ladder is in accordance with 6mt suspension ranges
- NEMA VE 1 Standard compliance and certification
- Maximum cable bearing with Extra Heavy Duty Type Structure
- High quality raw material selection (Corten A - SS 316L)
- High Production Capacity
- Fast Track delivery period
- Flexible Production against different specifications
- With the special form of the side rail, cable bearing capacity is upgraded
- Tested for hazardous conditions
- According to DIN4102-12 standard, it was tested at a temperature of 1000 °C for 90 minutes
- It has successfully passed the -70 °C degree test

### Applications:

- Thermal Power plants
- Combine Cycle Power Plants
- Geothermal Power Plants
- Nuclear Power Plants
- Production Facilities (Glass, Steel, Cement etc.)
- Refineries
- Oil Platforms
- LNG Terminals and Pumping Stations
- Urea and Amonium Plants

## ELINEKCA AL Aluminium Cable Ladder Systems

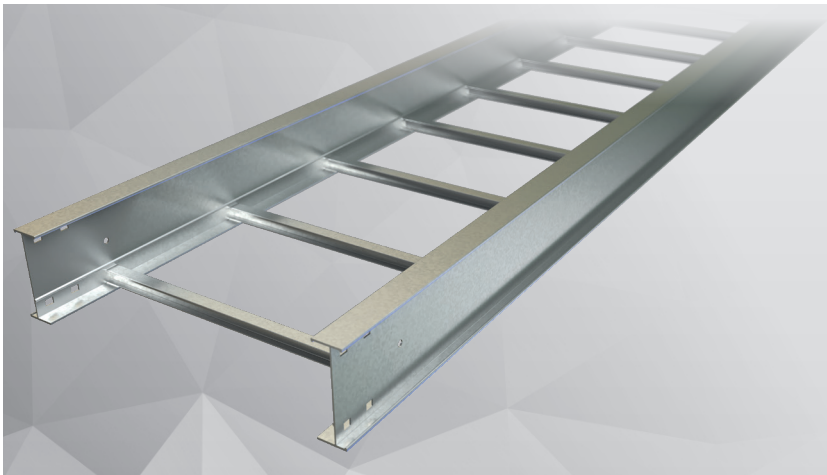

### Overview

E-Line KCA AL aluminium cable ladder sections are designed to comply with NEMA VE-1 and IEC 61537 load requirements.

### Features:

- 6mt the is standard length and construction of the ladder is in accordance with 6mt suspension ranges
- NEMA VE 1 Standard compliance and certification
- Maximum cable bearing with Extra Heavy Duty Type Structure
- Material: Extruded Aluminum Alloy 6063-T6 (Also called marine grade Aluminum and copper-free Aluminum)
- High Production Capacity
- Fast Track delivery period
- Flexible Production against different specifications
- With the special form of the side rail, cable bearing capacity is upgraded
- Tested for hazardous conditions

### Applications:

- Thermal Power plants
- Geothermal Power Plants
- Hydroelectric Power Plants
- Nuclear Power Plants
- Heavy Industry Production Facilities
- Refineries
- Oil Platforms
- LNG Terminals and Pumping Stations
- Urea and Amonium Plants
- FSRU Projects
- Floating Solar Plants



## ELINEA-A Support - Accessories Systems

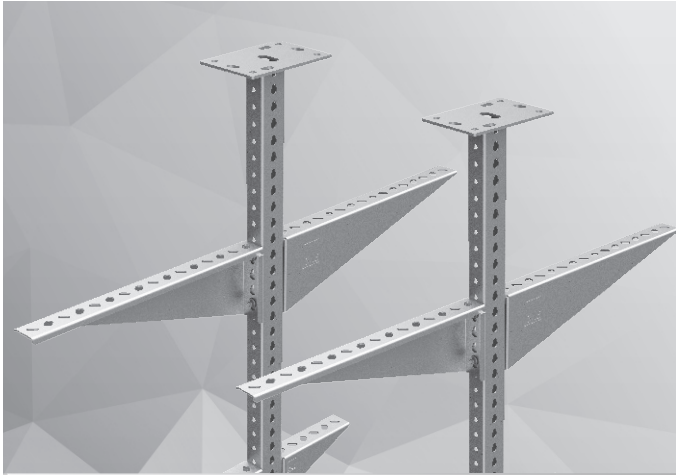

### Overview

E-LINE A-A series and E-Line Seismic suspension systems are used in buildings and factories; in concrete or steel structures to carry Busbar, Conduit, Cable Ladder, etc. Systems appropriately. Service and light service-type suspension types diversities are available according to the weight of the system to be carried.

### Features:

- Certified seismic suspension range
- Light service-type and heavy service-type suspension types
- Produced with a wall thickness of 2mm to 6mm. (Only AT3 and KT types are produced with 1.5mm thickness)
- Pre-galvanized and hot-dip alternatives
- Hot-dip production in all welded supports
- Load deflection graphs where carrying capacities of all supports are shown
- Plating which is durable against 400 hour salt test to avoid corrosion of consumable connection elements such as rod, bolt, nut, etc.
- Customized support production
- Supports with fire resistance certificate (E30, E60, E90)

## MFIX Electro-Mechanical Support and Suspension Systems

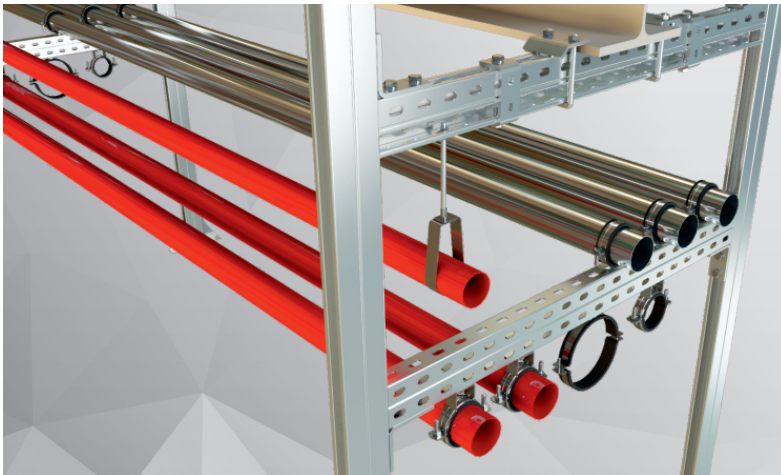

### Overview

MFIX offer the most convenient and professional solutions for mechanical installation suspension project by their high quality and practicability. While ensuring fast and easy assembly features through their modular structure, also prevent formation of applications that might yield adverse outcomes. Our products are ensured to have long service life by being exposed to hot-dipping process. Suspension parts can be coated by special coating methods in accordance with customer requirements.

### Features:

- Pre-galvanized and Hot-Dipping alternatives
- Suspension system varieties of Light, Medium and Heavy-Duty type
- Coating resistant to salt test of 400 hours for the purpose of corrosion prevention of products such as Stem Bar, Bolt and Nuts of switch material fittings
- Mechanical suspension solutions specific to customer requirements.
- Design programs and expert engineering support is available specific to electromechanical suspension systems.

### Applications:

- High-rise buildings
- Hotels, shopping malls
- Industrial buildings
- Hospitals
- Petro-chemical plants
- Subways, tunnels

## ELINEBINRAK E-LINE Binrak (G Profile) Tray Series

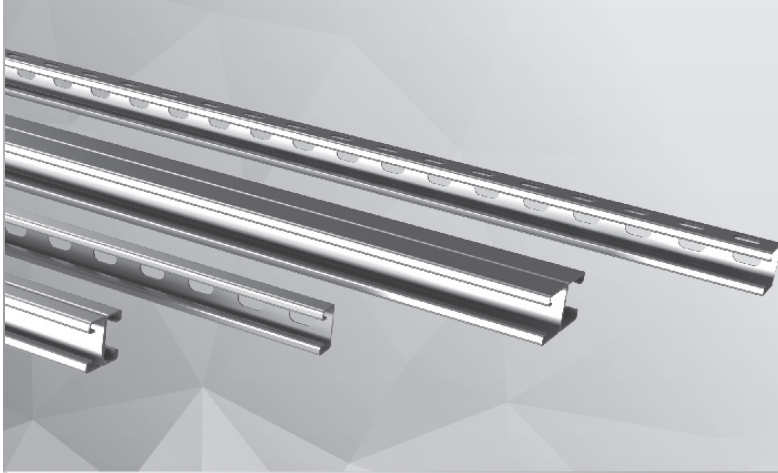

### Overview

E-LINE Binrak Trays Series are produced Pregalvanized in Standard heavy service type in TSE and ISO 10143 standard, hot-dip in TS EN ISO 1461 standard and with 3m length with Stainless steel (304, 304L, 316, 316L) as standard. It is designed to carry the support systems in facilities and buildings as well as mechanical, electrical and industrial products.

### Features:

- In Heavy Service Type
  - In 41x21 mm and 41x41mm sizes as standard
  - Standard  $t = 1,5/2/2,5$  thicknesses are produced.
  - In 1.5/2/2,5 thicknesses
  - Welding different surfaces of Binraks to each other to create stronger structures and brackets
  - Large range of connection accessories and connection parts with 6 mm thickness (Production of standard connection accessories in special dimensions)
  - Quick assembly convenience from each point on railed surface
  - Possibility of using with suspension systems in mechanical, electrical and industrial areas
- Quick assembly with conduits, cable ladders, pipe supporting systems without requiring welding or boring thanks to its perforated structure
  - Standard productions in hot-dip and then special protective plating on hot-dip special to EAE in TS EN ISO 1461 standard; galvanized option complying with TS EN 10143 standards (pre-galvanized) and Stainless steel (304, 304L, 316, 316L)

## ELINERSP Industrial Rectangular Profile Systems

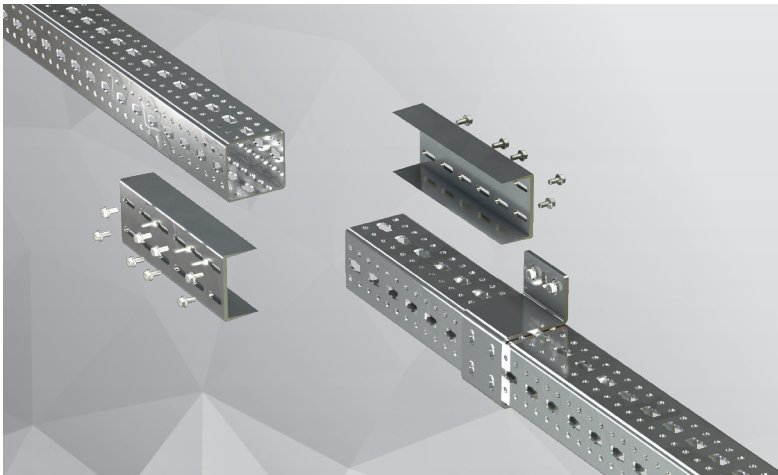

### Overview

E-Line RSP Rectangular Profile System is a specially designed solution to meet your industrial connection needs. With the unique advantages of the tapered threaded bolts used in this system, it offers significant gains in terms of labor, cost, and performance.

### Features:

- Provides a 4-fold time advantage in assembly speed compared to traditional manufacturing.
- Allows for creative and flexible applications due to its modular structure and accessories.
- The use of intelligent bolts at connection points eliminates the need for nuts and washers.
- Does not require welding and painting, offering material and labor advantages.
- Provides high-capacity solutions for long span openings and heavy-load conditions.
- Optional Hot-Dip Galvanizing and Stainless Steel material choices are available for corrosive environments.

### Applications:

- High-rise buildings
- Hotels, shopping malls
- Industrial buildings
- Hospitals
- Petro-chemical plants
- Data center
- Subways, tunnels



## ELINESEISMIC Seismic Bracing Systems



### Overview

EAE Seismic suspension systems offer rigid solutions for earthquake protection for busbar trunking, cabling and other building services installations that are designed for steel supports and spaceframe connections offer fast and easy mounting.

### Faster

Up to 50% mounting cost savings and fast installation compared to non-rigid systems.

### Maximum Application

Since connection from one location is sufficient, maximum compatibility with existing installations.

### Can be Installed at a Later Time

It can be installed in active facilities on the current cabling system without any dismantling.

### Seismic Support Systems Product and Service Groups

- E-Line Seismic supports
- E-Line Seismic rod reinforcements
- E-Line steel beam supports
- E-Line pipe beam supports
- E-Line seismic technical supports

### Solutions

- Busbar, cable trays, cable pipe installations seismic protection systems
- Mechanical and hygienic installations seismic protection systems
- Ventilation ducts seismic protection systems
- Suspended equipment seismic protection systems

## ELINESOLAR MOUNTING SYSTEMS



### Overview

E-Line Solar Mounting Systems offers reliable and fast assembly on site and roof applications with its high quality, project-specific design, patented and special assembly system. EAE reflects its manufacturing, design and market experience of 50 years and manufacturing and service policy without compromising from quality to Solar Power sector applications. The corporation therefore has the capability of performing project-specific design and manufacturing for domestic and overseas projects to accomplish and adopt new technologies in renewable energy.

### Features:

- Ability to perform the entire process in a single plant
- Tested and approved model frameworks
- Project based flexible special design and manufacturing facilities
- Expedited and quality manufacturing
- Domestic Goods Certificate for all products

## ELINETROLLEY BUSBAR Trolley Busbar Systems 35A...250A

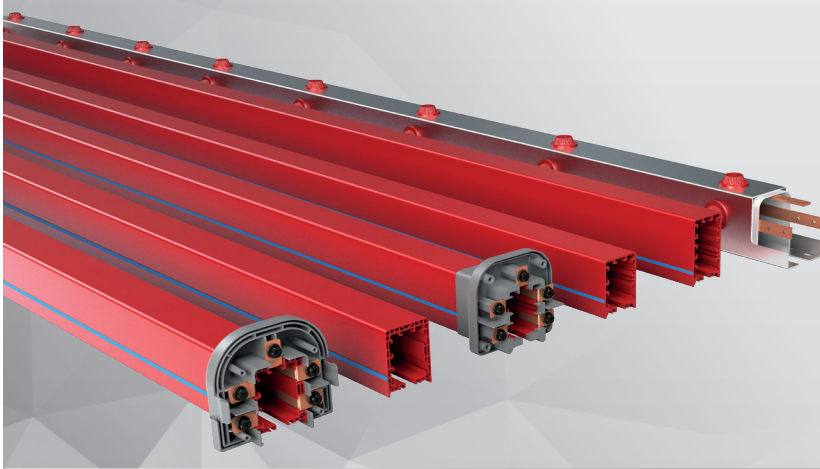

### Overview

E-Line TB series and URC series Trolley Busbar Systems are designed to supply power to moving machines. The busbar's current reception carrier has carbon brushes and is mechanically fixed to the moving together with the machine.

### Features:

- 35A...250A current ranges
- Standard 4 or 7 conductors (3, 5, 6 conductors on request)
- Uninterrupted copper conductors
- PVC body
- Standard 4m lengths

### Applications:

- Hoists and cranes
- Confection plants
- Moving assembly lines
- Automated warehouses
- Similar places

## ELINEURC Trolley Busbar Systems 90A...1000A



### Overview

URC (Uni-Rail Conductor) Busbar systems are the systems where each conductor is installed as a separate line and the current reception cars act together with the machine that will use the energy to realize the continuous power reception.

### Features:

- 90A...1000A current ranges
- Aluminium, copper or galvanized steel conductors
- PVC exterior insulation
- 6m for aluminium conductors and 4m for copper and galvanized steel conductors are standard lengths
- Suitable for indoor and outdoor

### Applications:

- Port, construction and industrial cranes
- AS/RS storage systems
- Moving playground systems
- Moving door and ceiling systems
- Installation and testing lines
- Monorail systems
- Lift system



## ELINEFL/FLD Indoor Busbar Trunking Systems 32A



### Overview

Stylish, safe and functional busbar trunking system eliminating cable stacks. Offers solutions for structural cabling such as mains, UPS, data, phones etc. through surface mounted skirting or at table level environments at offices, technology market, stores, hospitals or workshops. Offers power transfer without the need for additional cable, easily and safely from any point. Thanks to its fixing brackets, it can be mounted on any structure and any surface.

### Features:

- Manufactured in accordance with IEC 61439-6 standard. It has DEKRA and TSE certifications.
- FL busbar 32A-250V sockets are 16A-250V with child protection.
- Has IP2XB protection level against finger contact and dust.
- Includes a locking mechanism that prevents removal of the plug.
- Single phase single circuit (3 conductors); L+N+(PE) (FL-I)
- Can be cut or extended as required.
- Suitable for surface mounting and is manufactured in white (RAL 9003) in standard 1m or 2m options.

### Applications:

- Offices
- Workshops
- Stores
- Hospitals
- Laboratories
- Airports
- Schools

## DABLINE Raised Floor Power Distribution Systems 63A-80A

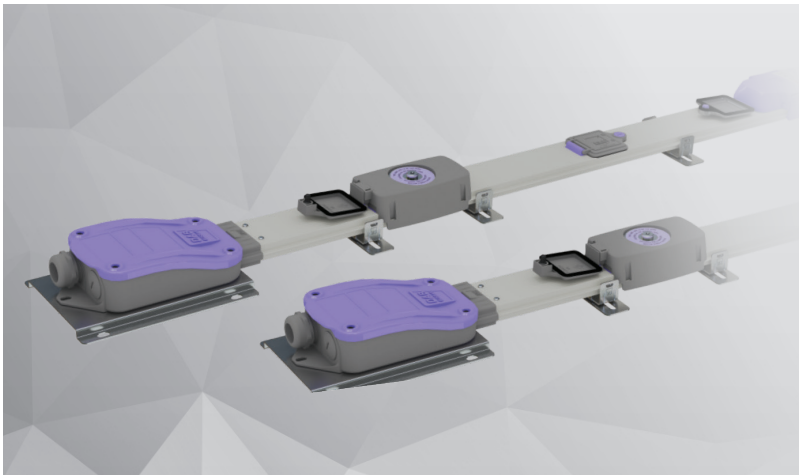

### Overview

DABLINE busbar systems, which has different colour options, is used for raised floor applications in offices. The small size of DABLINE makes it possible to install the system into very narrow places even up to 65mm floor height.

Does not require cable duct, cable, junction and connector. Manufactured in either 63A or 80A current rated versions with tap off plugs rated 13A to 32A.

### Features:

- Manufactured in accordance with IEC 61439-6 standard. It has DEKRA and TSE certifications.
- The body with IP55 protection level includes outputs at every 30 or 60cm
- With completely insulated conductors and silver coated tulip formed enhanced contacts offers perfect and safe utilization.
- Each busbar length is equipped with integral adjustable fixing brackets.
- With its ultra slim structure and horizontal utilization properties and output plug options, it can be used comfortably beneath a 10cm raised floor.

### Applications:

- Banks,
- Business centres,
- Modern offices,
- Hotels,
- Hospitals,
- Cinema and theatre buildings,
- Conference centres,
- Courses,
- Resorts etc.
- Any other application with a raised floor in the building.

## ELINENDK Modular and Compact Solutions For Under Floor and Raised Flooring

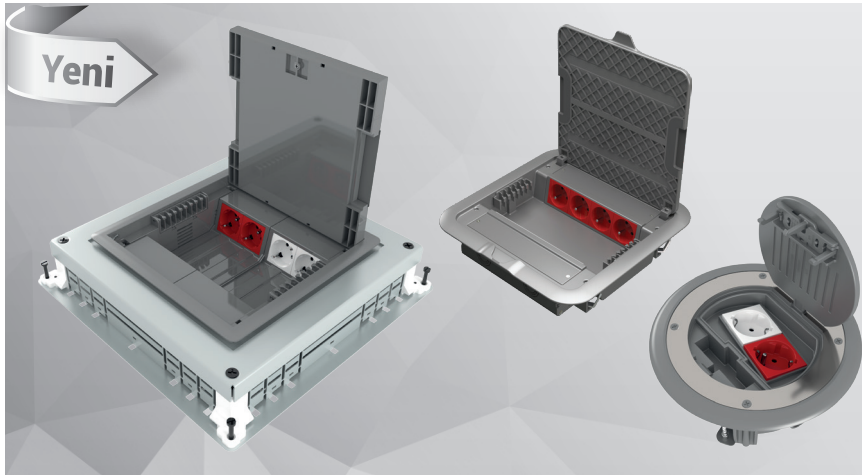

### Overview

Stylish, safe and innovative design, modular and compact solutions... The underfloor and raised floor power distribution systems that save office etc environments from cable stacks and offer streamlined cabling. Can be adapted when offices or work places are moved around or capacity increases. Offers more sturdy options against the elements such as pressure, humidity and vibration.

### Features:

- Socket box options with 3, 8, 16 or 24 module capacity
- Compliant with circuit protection elements such as MCB, RCD and RCDBO.
- Manufactured with EN 50085-2:2008 standard compliance, has DEKRA and TSE certificates.
- All plastic parts are "halogen free" and compliant to 960°C glow wire test as per IEC 60965, with V2 flame retardent class as per UL94.
- DK-F5 model has 5cm body.
- Socket boxes with IP66 protection class are water proof, with circular or rectangular plastic or metal body options and can be utilized in any building with floors where damp or wet cleaning is adopted.

### Applications:

- Banks
- Offices
- Hospitals, hotels
- Schools and classrooms
- Malls
- Conference centres
- Call centers
- Trading Rooms
- Cinema and theatre buildings
- Industrial plants
- Tourist facilities

## ELINEMINI Mini Series Pop-up and IP66 Outlet Boxes

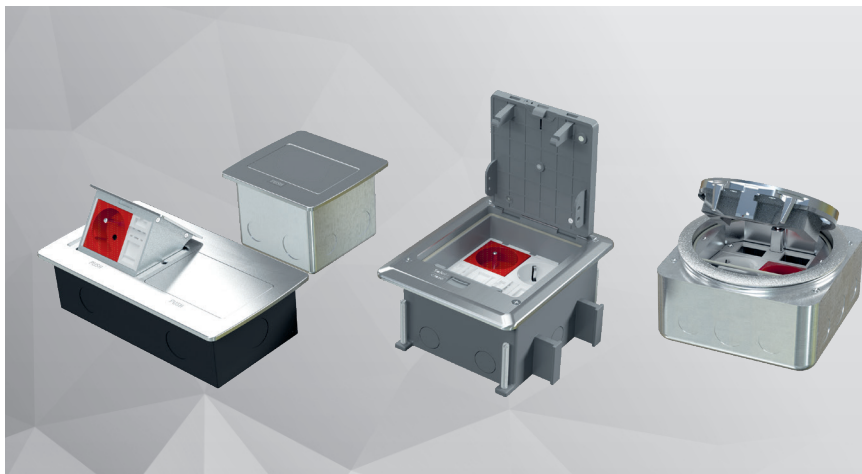

### Overview

Add value to your working environment with the pop-up series products. Get power from the nearest point with its accessibility and stylish finish. Can be used in tabletop, under screed or raised floor applications. Select the module (3/6 modules) you need and customize them using the range of available outlets.

### Features:

#### IP40 SERIES PRODUCTS:

- Soft opening covers
- Plastic socket plate for modular type (45x45mm and 22.5x45mm) power, data, telephone and multimedia outlets
- Suitable structure for desk, raised floor and under screed applications
- 3 Modules and 6 Modules options

#### IP66 SERIES PRODUCTS:

- Two stage opening cover structure
- Plastic socket plate for modular type (45x45mm and 22.5x45mm) power, data, telephone and multimedia outlets
- Suitable structure for underscreed and raised floor application and back box with pipe entry.
- Six (6) modules outlet capacity
- Special locking mechanism on the cover eliminating cable crushes

### Applications:

- Residential Buildings
- Shopping Centres
- Airports
- Factory / Workshop
- Administrative Buildings Offices
- Hotels
- Hospitals / Health Centres
- Sport Centres



## ELINESMART Multi-Outlet Extension Blocks



### Overview

Products ensure high ease of use, depending on your personal needs and preferences with modular type power and low voltage sockets. Products are 7 different types, according to size in socket needs, universal and modular design makes it suitable to accept any brand of socket. Built-in type or free standing on the office desk and furniture; offers flexible and definitive solution for mains, UPS, data, telephone and multimedia needs.

### Features:

- The ELINE SMART range offers comfort, style and functionality for users in living and working environments; available equipped or non- equipped to accept power and data sockets.
- Compatible structure with offices, meeting rooms, every desk and in specific work areas and open office furniture.
- Energy and low-voltage sockets can be used optional wide cable terminations for today's office needs.
- Modular structure and innovative design with anodized aluminium body and polycarbonate covers, 8, 10, 12, 14, 16 and 18 modules are standard production capacity. Aesthetics and high-performance products can be produce optional comfortable with special production opportunities in different sizes and equipment.

### Applications:

- Banks
- Business Centres
- Modern offices
- Hotels
- Hospitals
- Conference centres
- Courses
- Resorts etc.

## ELINEWSB Wall Mounted Modular Socket Boxes



### Overview

Having capacity options from 4 modules up to 16 modules, WSB Wall Mounted Modular Socket Boxes offer various options on all types of walls thanks to their modular and interlaced sockets and MCB/RCD cases. MCB/RCD can be controlled at any time and offers convenience due to the transparent inspection cover on the enclosure.

### Features:

- The modular structured 45x45mm mains and UPS sockets and 22.5x45 mm practical and ergonomic socket cases are suitable for phone, data and multimedia sockets which enables you to save time due to the easy installation process.
- Mounting cases are available for practical and easy installation in brick and concrete walls flush mounted applications.
- Modular type interlocking socket cases, DIN rail case for MCB/RCD, socket plates; nylon-6 (PA6), the transparent cover of the MCB/RCD cases are manufactured from polycarbonate (PC), front cover and S/A mounting boxes are manufactured from ABS material, all materials are halogen free and have flame proof insulation.

### Applications:

- Industrial facilities
- Laboratories
- Hospitals
- Production areas
- Shopping malls
- Call centers
- Administration buildings offices
- Hotels
- Schools & private teaching institutions
- Banks

## ELINEMULTIBOX Socket Combination Box & Fuse Boxes



### Overview

Equipped and/or empty socket combination and fuse (distribution) box solutions for factories, construction sites, workshops and working environments. Industrial sockets with CEE standard and fully equipped ready-to-use products are currently considered important for technical working environments such as factories, workshops and construction sites. So, equipped and/or can-be-equipped "socket combination boxes" and "fuse distribution boxes" as well as modular alternatives that can meet rapidly changing and continuously increasing needs, plus flexible, sound, ergonomic, safe and aesthetic design options are offered according to the requirements and preferences for living and working environments.

### Features:

- ABS raw material with special modular structure and IP44 frame
- 230/400V AC operating voltage
- Various combination option up to maximum 125A
- 16A, 240V cover type panel sockets (schuko) and structure complying with CEE standard cover type industrial socketing mounting up to 63A-415V
- 13 modules for miniature circuit breaker (MCB) and/or residual current circuit breaker (RCD) device, transparent cover compartment with breakable plate and that is padlockable
- Standard Neutral (N) and earth (PE) busbars with add-on modular structure together with connecting terminals
- Possibility to be used as a "fuse and junction box" together with lidded terminal module, and breaker module with transparent cover
- When used as a MCB and junction box, alternative lower cover with numerous options convenient for cable outlets for various functions are available.

### Applications:

- Factories, workshops and industrial areas
- Construction sites
- Business Centres and offices
- Warehouses
- Car Parking Lots
- Common technical areas
- Entire electrical installation areas requiring socket combination box and MCB box





# DESIGN FORM

Member List		
Serial No	Type	Pcs.
<div style="background-color: #cccccc; width: 100%; height: 100%;"></div>		
Company : Project : Project No :		
Name : Date : Signature :		
Prepared by		



Please use this page after copying.

# DESIGN FORM

Member List		
Serial No	Type	Pcs.
Company : Project : Project No :		
Name : Date : Signature :		
Prepared by		
<div style="text-align: right; padding-right: 10px;">  </div>		

Please use this page after copying.





### EAE REFERENCES

- |                          |              |                                  |              |                |
|--------------------------|--------------|----------------------------------|--------------|----------------|
| AFGHANISTAN              | PALESTINE    | KYRGYZSTAN                       | NORWAY       | OMAN           |
| GERMANY                  | FINLAND      | CYPRUS                           | UZBEKISTAN   | URUGUAY        |
| UNITED STATES OF AMERICA | FRANCE       | COLOMBIA                         | PAKISTAN     | JORDAN         |
| ANGOLA                   | GHANA        | CONGO                            | PERU         | VIETNAMESE     |
| ARGENTINA                | GUINEA       | DEMOCRATIC REPUBLIC OF THE CONGO | POLAND       | VIRGIN ISLANDS |
| ALBANIA                  | SOUTH AFRICA | CONGO                            | PORTUGAL     | YEMEN          |
| AUSTRALIA                | SOUTH KOREA  | KOSOVO                           | ROMANIA      | NEW ZELAND     |
| AUSTRIA                  | GEORGIA      | KUWAIT                           | RWANDA       | GREECE         |
| AZERBAIJAN               | CROATIA      | NORTH MACEDONIA                  | SENEGAL      | ZAMBIA         |
| BAHRAIN                  | INDIA        | LATVIA                           | SERBIA       | ZIMBABWE       |
| BANGLADESH               | HOLLAND      | LIBERIA                          | SINGAPORE    |                |
| BELGIUM                  | NETHERLANDS  | LIBYA                            | SLOVAKIA     |                |
| BELARUS                  | ANTILLES     | LITHUANIA                        | SLOVENIA     |                |
| UAE EMIRATES             | HONG KONG    | LEBANON                          | SOMALIA      |                |
| UNITED KINGDOM           | IRAQ         | LUXEMBOURG                       | SRI LANKA    |                |
| BOSNIA AND HERZEGOVINA   | IRELAND      | HUNGARY                          | SYRIA        |                |
| BULGARIA                 | SPAIN        | MADAGASCAR                       | SAUDI ARABIA |                |
| ALGERIA                  | SWEDEN       | MALAYSIA                         | CHILE        |                |
| Djibouti                 | SWITZERLAND  | MALTA                            | TAJIKISTAN   |                |
| CZECHIA                  | ITALY        | MAURITIUS                        | TANZANIA     |                |
| DENMARK                  | ICELAND      | MEXICAN                          | TATARSTAN    |                |
| INDONESIA                | CAMBODIA     | SWEETCORN                        | THAILAND     |                |
| ESTONIA                  | CAMEROON     | MOLDOVA                          | TAIWAN       |                |
| ETHIOPIA                 | MONTENEGRO   | MYANMAR                          | TUNISIA      |                |
| MOROCCO                  | TRAIN        | NEPAL                            | TURKMENISTAN |                |
| IVORY COAST              | KAZAKHISTAN  | NIGER                            | UKRAINE      |                |
|                          | KENYA        | NIGERIA                          |              |                |



EAE Elektrik A.S.  
Head Office  
Akcaburgaz Mahallesi,  
3114. Sokak, No:10 34522  
Esenyurt - Istanbul - TURKEY  
Tel: +90 (212) 866 20 00  
Fax: +90 (212) 886 24 20

EAE DL 3 Factory  
Busbar  
Gebze IV Istanbul Makine ve Sanayicileri  
Organize Bolgesi, 6. Cadde,  
No: 6 41455 Demirciler Koyu,  
Dilovası - Kocaeli - TURKEY  
Tel: +90 (262) 999 05 55  
Fax: +90 (262) 502 05 69

EAE DL 1 Factory  
Cable Tray  
Gebze IV Istanbul Makine ve Sanayicileri  
Organize Bolgesi, 6. Cadde,  
No: 2 41455 Demirciler Koyu,  
Dilovası - Kocaeli - TURKEY  
Tel: 0 (262) 999 05 55  
Faks: 0 (262) 502 05 70

Please visit our website for the updated version of our catalogues.  
[www.eaelectric.com](http://www.eaelectric.com)



Catalogue 02-Eng. / Rev 07 / 1000 pcs. 30/01/2024  
S.S.

EAE has full right to make any revisions or changes on this catalogue without any prior notice.

